

# Lutz Double Diaphragm Pumps

## Model 1" Clamped Version (non-metallic)

### Typical application:

Drum and small tank transfer, pickling solutions, chemical feed

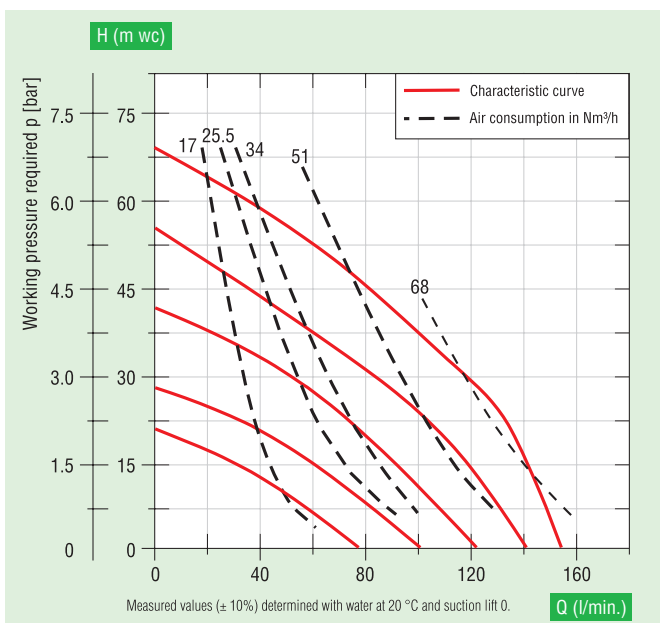

Suitable range of accessories see page 34 - 45.

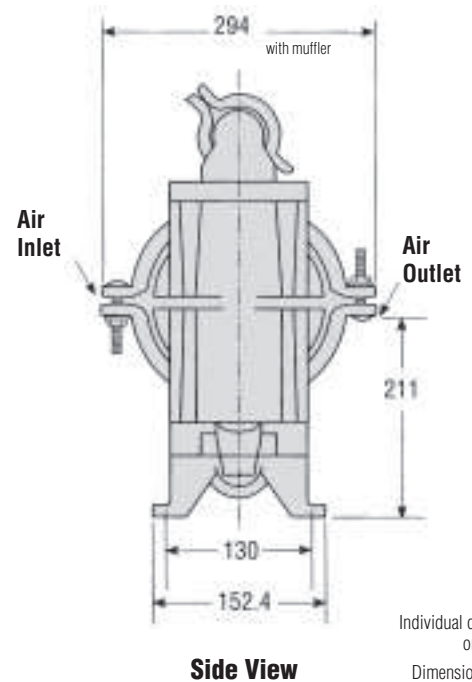
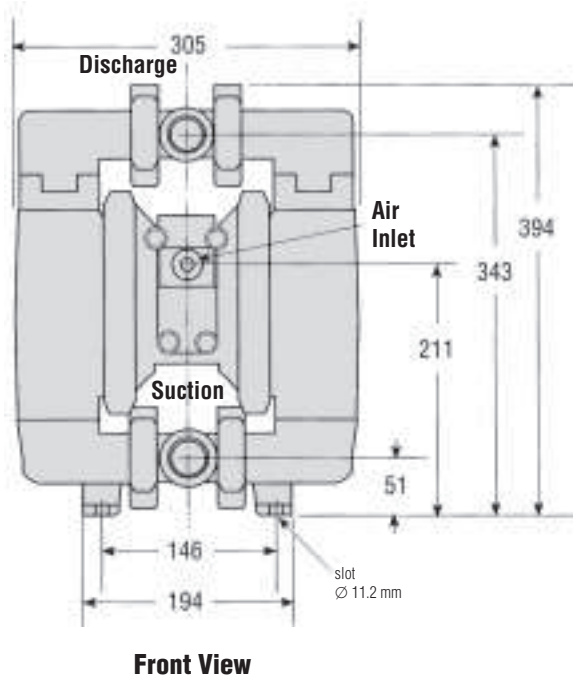

Individual datasheets on request.  
 Dimensions in mm