

Lutz Double Diaphragm Pumps

Model 1" Bolted Version (metallic)

Typical application:

Drum and small tank transfer, pickling solutions, chemical feed

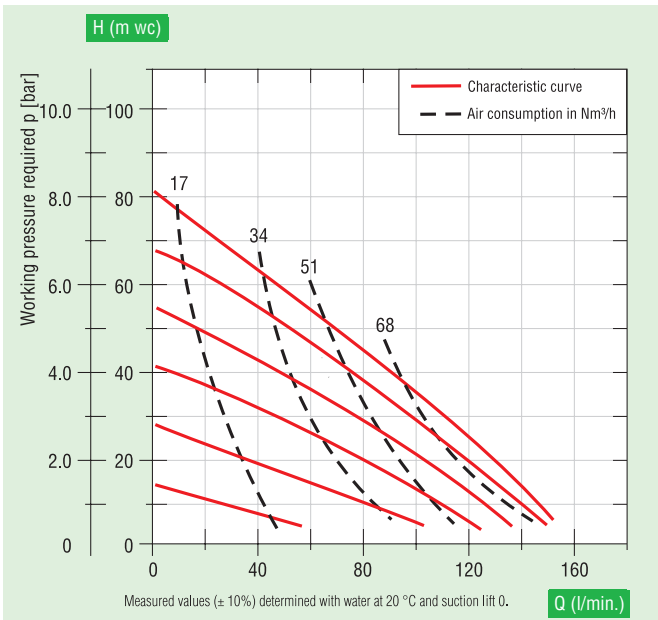

Explosion proof protection
Suitable range of accessories for avoiding electrostatic charge see page 34 - 45.

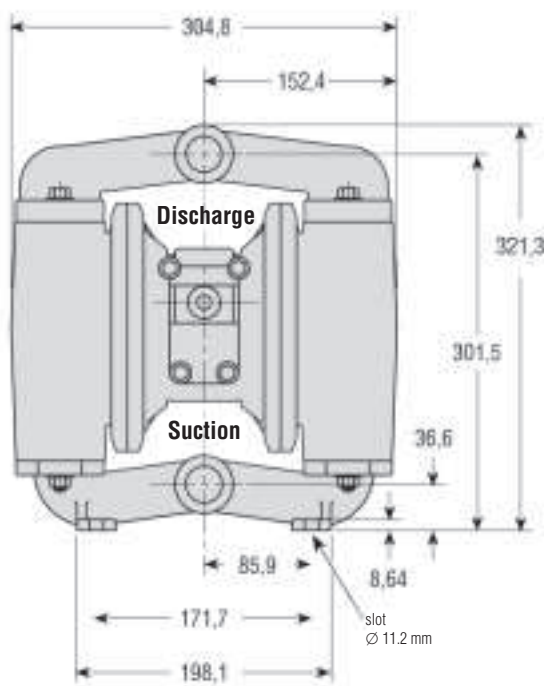

Front View

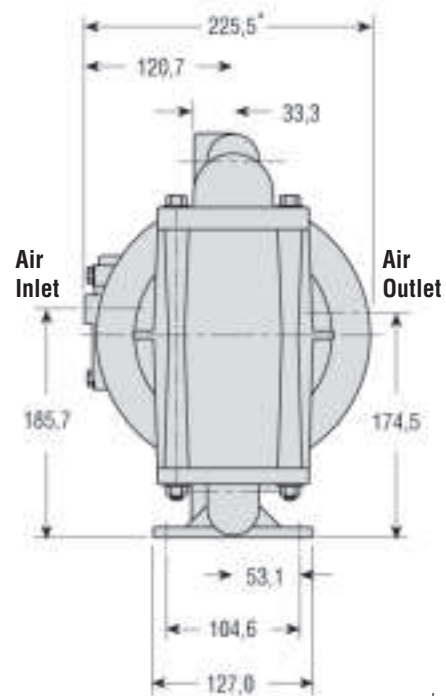

Side View

* Approximate Dimension with Muffler (260.4)

Individual datasheets on request.
Dimensions in mm